

AS12AC45H

STANDARD MATERIALS AND CONSTRUCTION

FRAME: 14-GA aluminum.

BLADE: 16-GA aluminum Airfoil exterior with 22-GA perforated aluminum interior surface.

INSULATION: Eco-Sound insulation

FINISH: Mill.

OPTIONS

Finish - Baked Enamel, Kynar, Anodize

Screen - 1/2" sq. mesh, aluminum (.051") or galvanized steel (.041")

NOTES

1. Nominal deductions will be made to the opening size given.

LOUVER SIZES

Min Panel	Max Single Panel
12"W x 24"H	60"W x 96"H

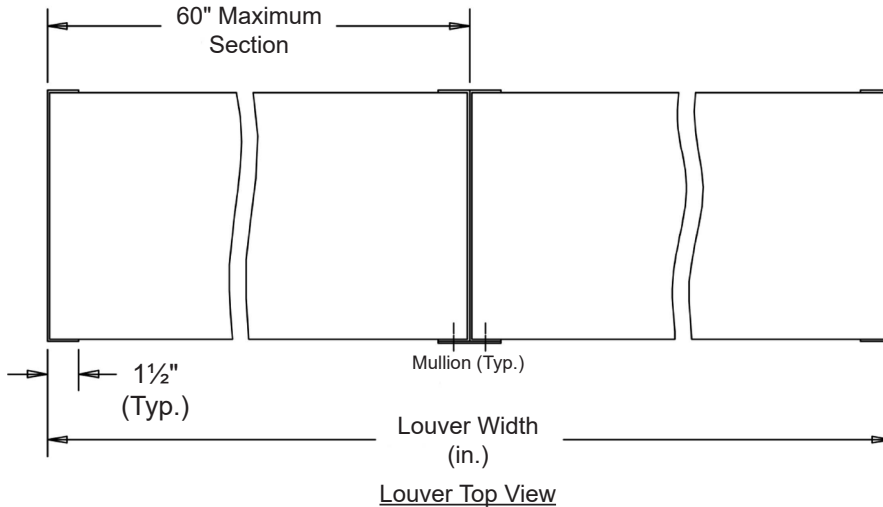
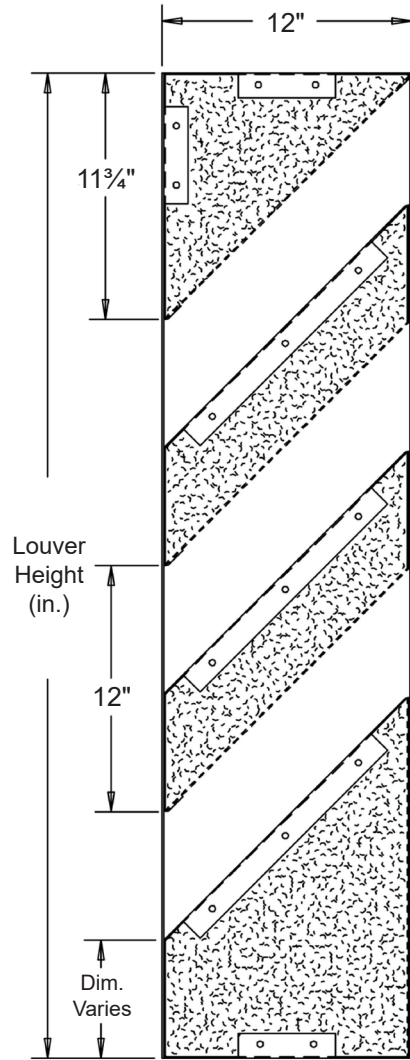

In the interest of product development, Airline Louvers reserves the right to make changes without notice.

											
Item #	Qty	Width	Height	Width	Height	Mullion	Type	Location			
		Opening Size		Louver Size			Screens			Union Made	
Arch. / Eng. :						EDR:		ECN:		Job:	
Contractor:											
Project:						Date:		DWN:		DWG:	

AS12AC45H

PERFORMANCE DATA

Ratings do not include effects of a screen.

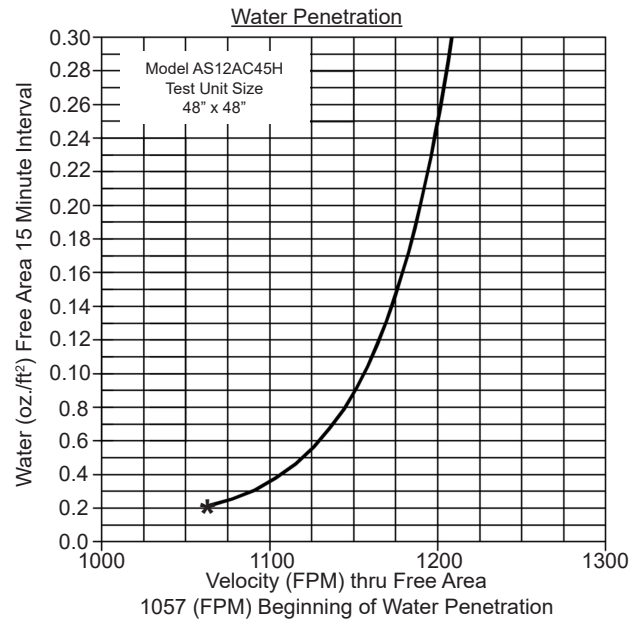
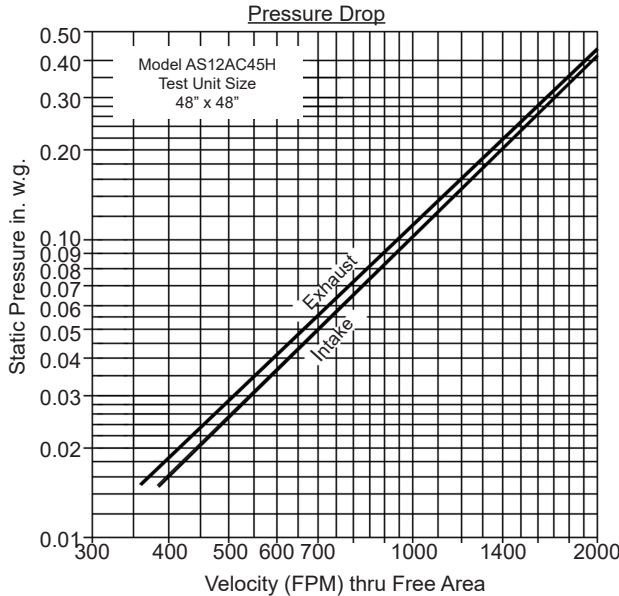

Intake air converted to standard air density.
Tested to AMCA Standard 500-L, Figure 5.5.

Transmission Loss

Octave Band	1	2	3	4	5	6	7	8
Frequency (Hz)	63	125	250	500	1000	2000	4000	8000
Sound Transmission Loss (db)	8	6	4	9	14	12	11	11
Free Field Noise Reduction	14	12	10	15	20	18	17	17

Attenuation

Octave Band Center Frequency (Hz)

Distance from Louver (ft)	Octave Band Center Frequency (Hz)							
	1 / 63	2 / 125	3 / 250	4 / 500	5 / 1000	6 / 2000	7 / 4000	8 / 8000
0'	14	12	10	15	20	18	17	17
10'	26	24	22	27	32	30	29	29
50'	40	38	36	41	46	44	43	43
100'	46	44	42	47	52	50	49	49
200'	52	50	48	53	58	56	55	55
500'	60	58	56	61	66	64	63	63
1000'	66	64	62	67	72	70	69	69

Attenuation chart above is a combination of the Model AS12AC45H sound transmission loss and the reduction of sound energy as a function of distance.

Free Area (sq. ft.)

		Width (in.)								
		12"	18"	24"	30"	36"	42"	48"	54"	60"
Height (in.)	24"	.27	.45	.63	.81	.98	1.16	1.34	1.52	1.70
	36"	.54	.90	1.25	1.61	1.97	2.33	2.69	3.04	3.40
	48"	.81	1.34	1.88	2.42	2.95	3.49	4.03	4.56	5.10
	60"	1.07	1.79	2.51	3.22	3.94	4.65	5.37	6.09	6.80
	72"	1.34	2.24	3.13	4.03	4.92	5.82	6.71	7.61	8.50
	84"	1.61	2.69	3.76	4.83	5.91	6.98	8.06	9.13	10.20
96"	1.88	3.13	4.39	5.64	6.89	8.14	9.40	10.65	11.90	

1020 Prince Frederick Blvd. Suite 305 • Prince Frederick, MD 20687 • Phone: (570) 420-7079 • Fax: (570) 420-7078